



US010622577B2

(12) **United States Patent**
Choi et al.

(10) **Patent No.:** **US 10,622,577 B2**
(45) **Date of Patent:** **Apr. 14, 2020**

- (54) **ORGANIC LIGHT EMITTING DISPLAY DEVICE**
- (71) Applicant: **SAMSUNG DISPLAY CO., LTD.**,
Yongin-si, Gyeonggi-do (KR)
- (72) Inventors: **Sang Hyun Choi**, Yongin-si (KR);
Young Nam Yun, Yongin-si (KR)
- (73) Assignee: **Samsung Display Co., Ltd.**, Yongin-si
(KR)
- (*) Notice: Subject to any disclaimer, the term of this
patent is extended or adjusted under 35
U.S.C. 154(b) by 0 days.

(21) Appl. No.: **15/847,077**

(22) Filed: **Dec. 19, 2017**

(65) **Prior Publication Data**
US 2018/0108856 A1 Apr. 19, 2018

Related U.S. Application Data

(63) Continuation of application No. 14/533,166, filed on
Nov. 5, 2014, now Pat. No. 9,876,186.

(30) **Foreign Application Priority Data**

Jun. 9, 2014 (KR) 10-2014-0069418

(51) **Int. Cl.**
H01L 51/50 (2006.01)
H01L 27/32 (2006.01)
H01L 51/52 (2006.01)

(52) **U.S. Cl.**
CPC **H01L 51/5036** (2013.01); **H01L 27/3209**
(2013.01); **H01L 27/3211** (2013.01); **H01L**
51/5265 (2013.01)

(58) **Field of Classification Search**
CPC H01L 51/5036; H01L 27/3211; H01L
27/3209; H01L 51/5265
See application file for complete search history.

(56) **References Cited**

U.S. PATENT DOCUMENTS

7,659,664 B2* 2/2010 Nshikawa H01L 27/3211
313/483
8,957,442 B2 2/2015 Seo et al.
(Continued)

FOREIGN PATENT DOCUMENTS

JP 2007-103358 A 4/2007
KR 10-2007-0056469 A 6/2007
(Continued)

OTHER PUBLICATIONS

Lee, Min Woo, et al., Asymmetric High Performance Hybrid
Tandem White OLEDs for Lighting Applications, SID 10 Digest,
pp. 1800-1803, OLED R&D Center, Samsung Mobile Display Co.,
Ltd. Giheung-Gu, Yongin-City, Gyeonggi-Do, Korea (2010).

Primary Examiner — William F Kraig

Assistant Examiner — Vicki B. Booker

(74) *Attorney, Agent, or Firm* — Lewis Roca Rothgerber
Christie LLP

(57) **ABSTRACT**

An organic light emitting display device includes a substrate
with a first emitting region adjacent a second emitting
region, a first anode in the first emitting region, a first
organic light emitting layer on the first anode, a second
anode in the second emitting region, and a second organic
light emitting layer on a part of the first anode and the second
anode. The second organic light emitting layer includes a
material different from the first organic light emitting layer.

12 Claims, 13 Drawing Sheets

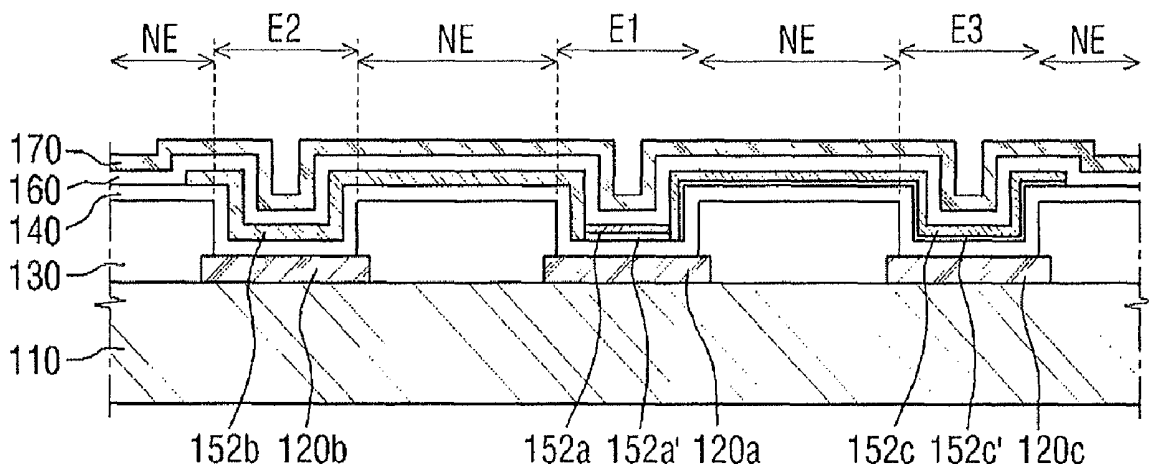

(56)

References Cited

U.S. PATENT DOCUMENTS

2008/0284324 A1* 11/2008 Chun H01L 27/3211
313/504
2013/0146853 A1* 6/2013 Lee H01L 27/3216
257/40

FOREIGN PATENT DOCUMENTS

KR 10-2009-0131404 A 12/2009
KR 10-2010-0041314 A 4/2010
KR 10-2014-0013854 A 2/2014

* cited by examiner

FIG. 1

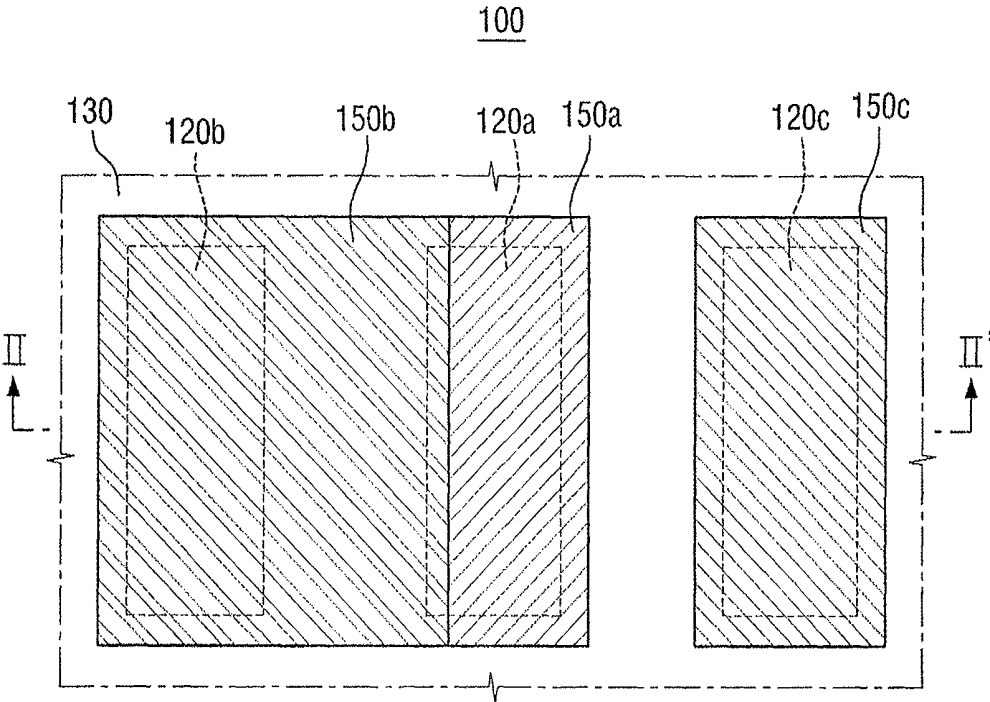

FIG. 2

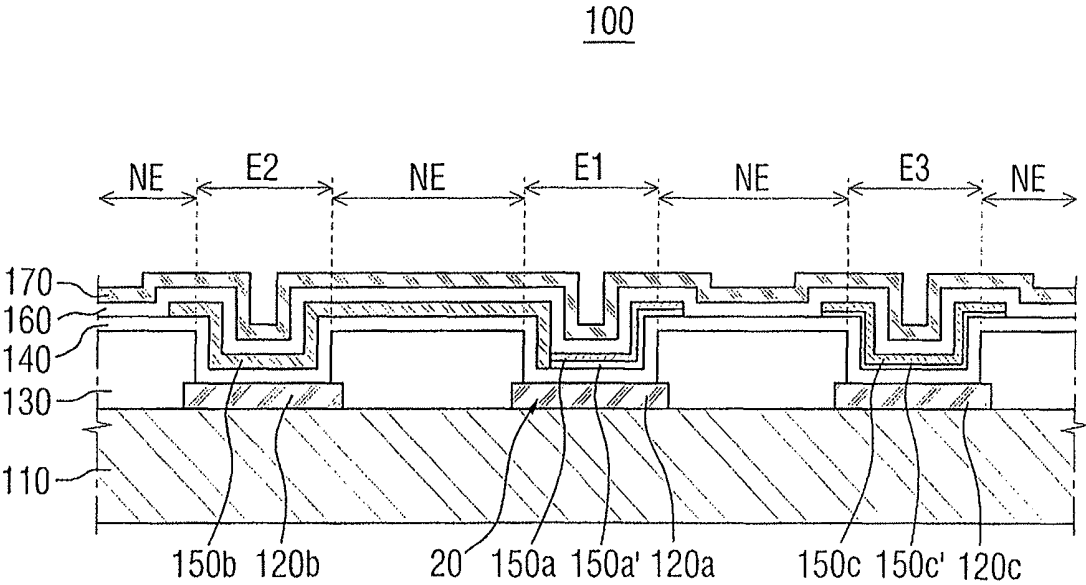

FIG. 3

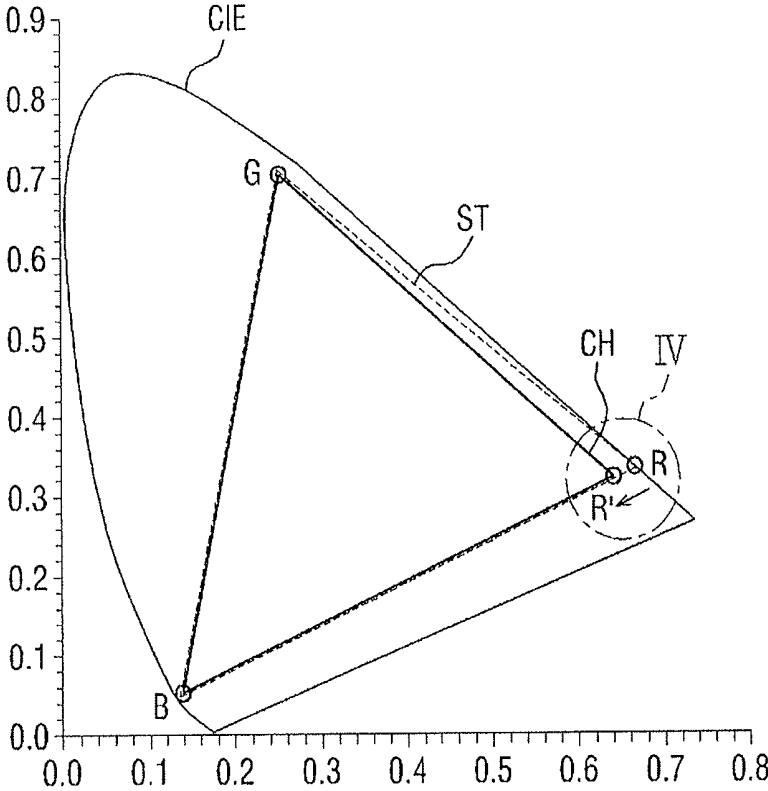

FIG. 4

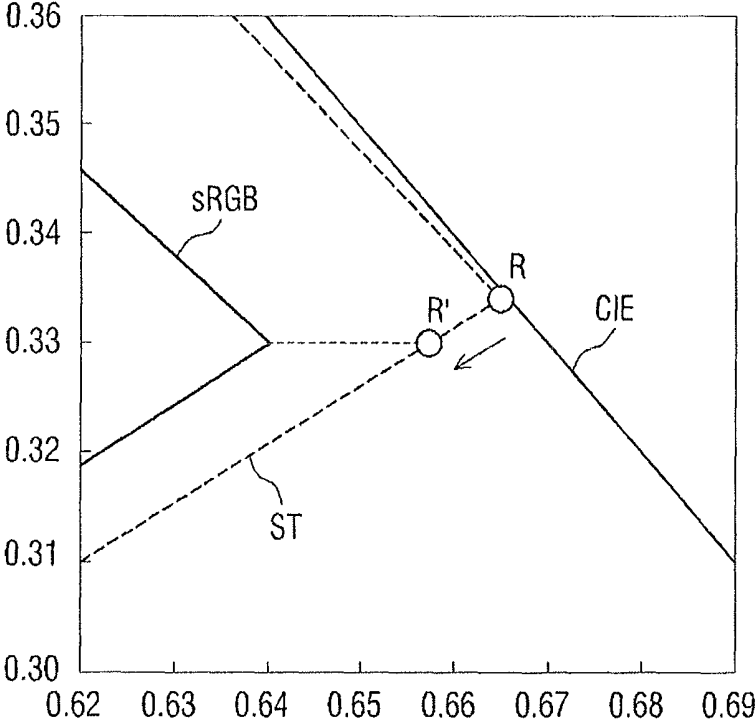

FIG. 5

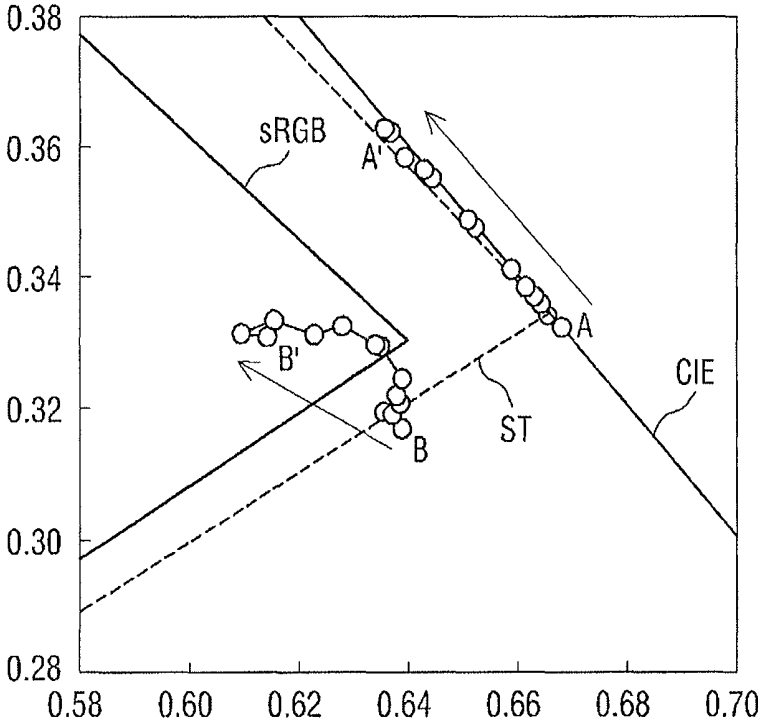

FIG. 6

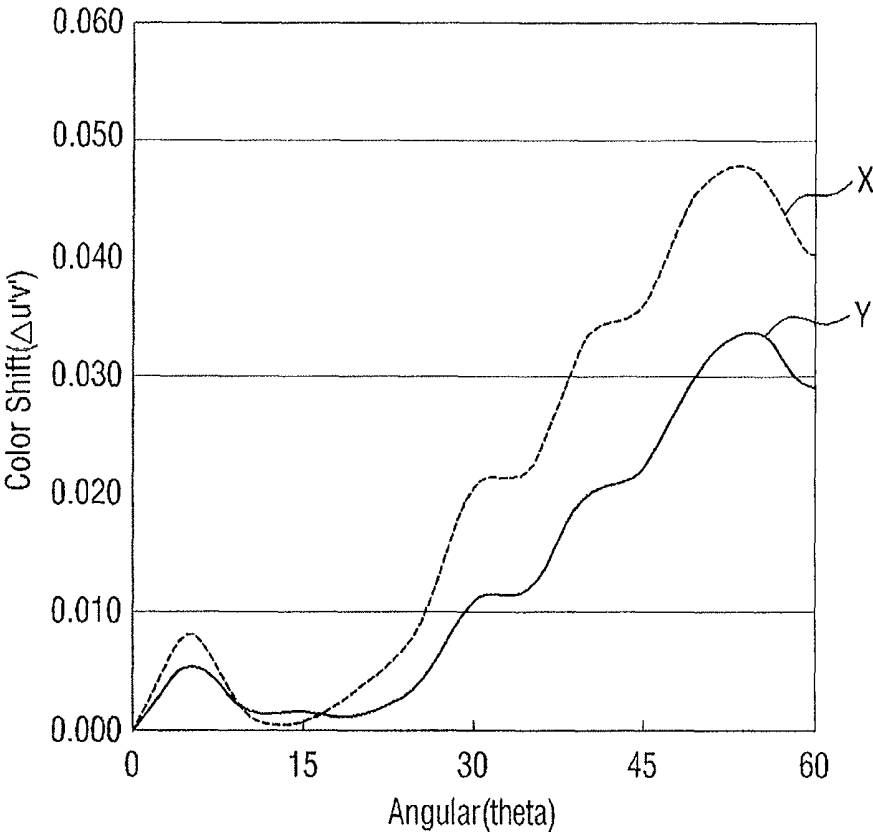

FIG. 7

101

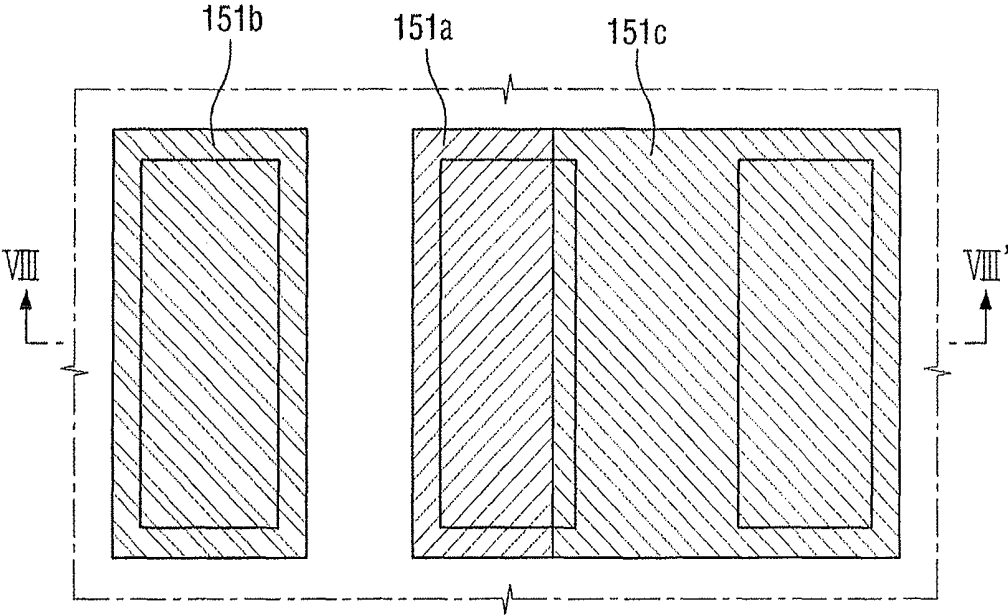

FIG. 8

101

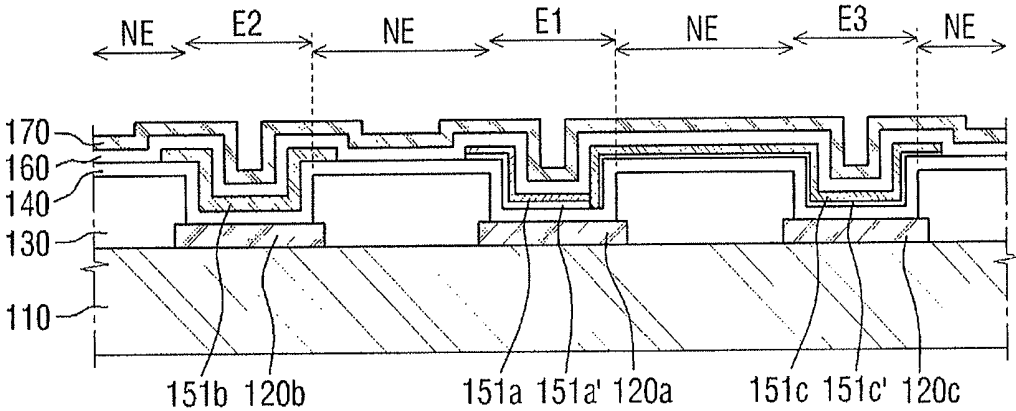

FIG. 9

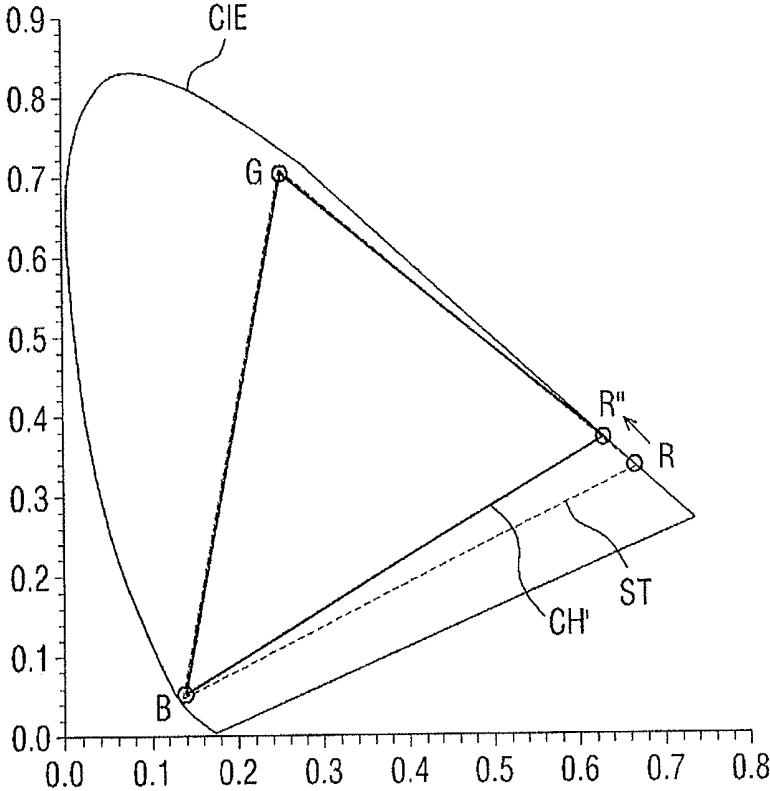

FIG. 10

102

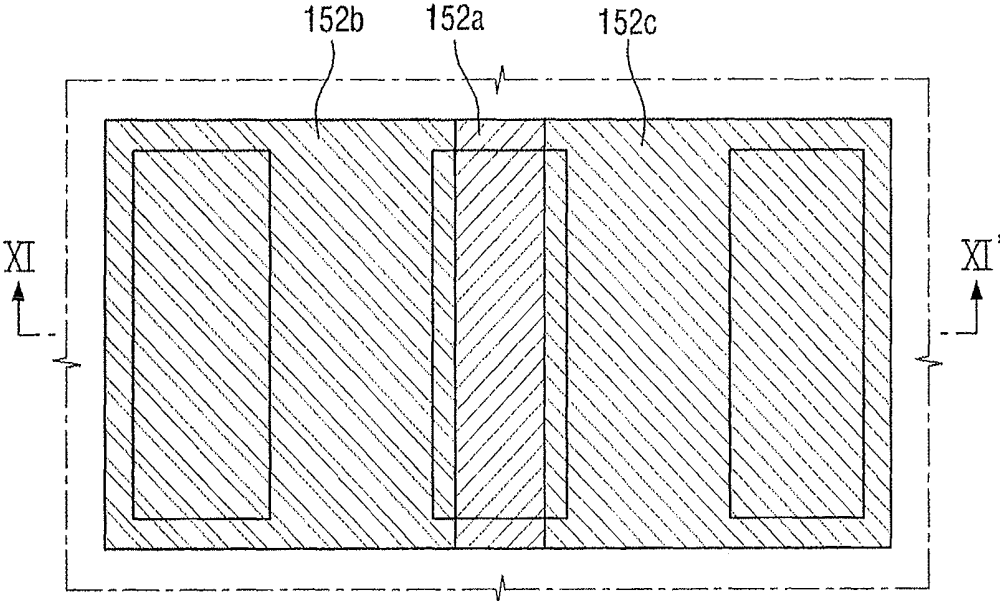

FIG. 11

102

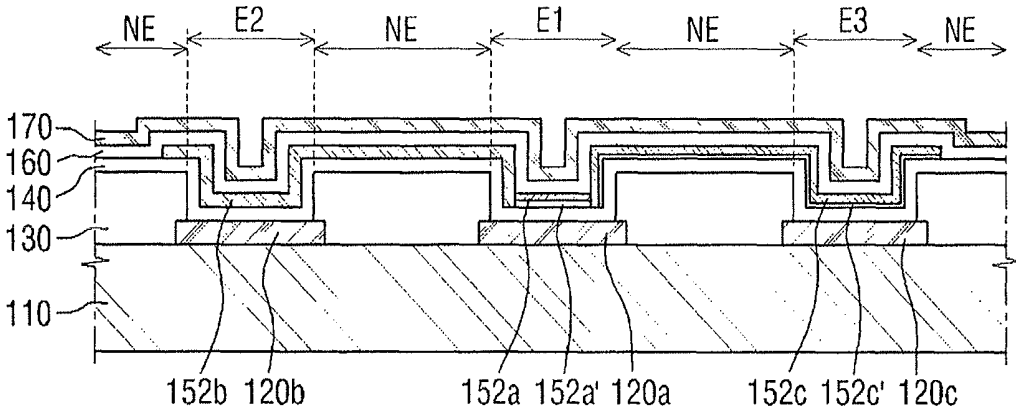

FIG. 12

103

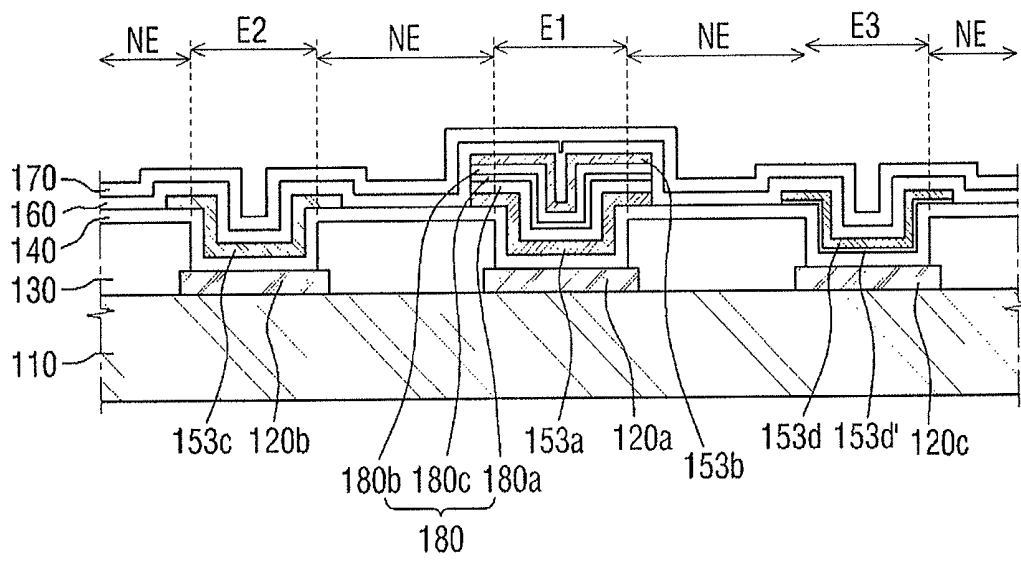
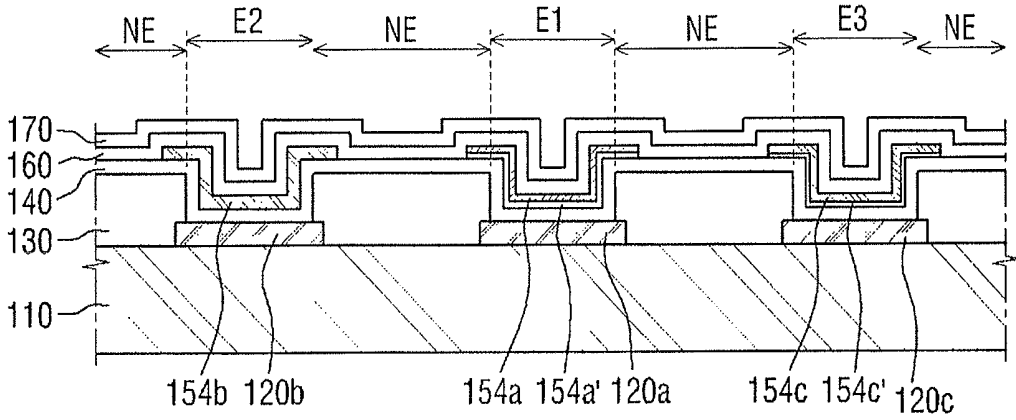

FIG. 13

104



**ORGANIC LIGHT EMITTING DISPLAY
DEVICE****CROSS-REFERENCE TO RELATED
APPLICATIONS**

This is a continuation application based on pending application Ser. No. 14/533,166, filed Nov. 5, 2014, the entire contents of which is hereby incorporated by reference.

Korean Patent Application No. 10-2014-0069418, filed on Jun. 9, 2014, and entitled, "Organic Light Emitting Display Device," is incorporated by reference herein in its entirety.

BACKGROUND**1. Field**

One or more embodiments described herein relate to an organic light emitting display device.

2. Description of the Related Art

An organic light emitting display device includes organic layers between an anode and cathode. The organic layers include an emitting layer, a hole injecting layer, a hole transport layer, an electron transport layer, and an electron injecting layer. In operation, electrons and holes generated by the anode and the cathode recombine in the emitting layer to emit light.

In one type of organic light emitting display device, a plurality of emitting layers are included to emit light of different colors. For example, a first emitting layer emits light of a first color, a second emitting layer emits light of a second color, and a third emitting layer emits light of a third color. A particular color is emitted by combining the light of the first to third colors.

SUMMARY

In accordance with one embodiment, an organic light emitting display device includes a substrate with a first emitting region adjacent a second emitting region; a first anode in the first emitting region; a first organic light emitting layer on the first anode; a second anode in the second emitting region; and a second organic light emitting layer on a part of the first anode and the second anode, the second organic light emitting layer including a material different from the first organic light emitting layer.

A part of the second organic light emitting layer may be on an edge portion of the first anode that faces the second anode. The second organic light emitting layer may extend from an upper portion of the second anode to an upper edge portion of the first anode that faces the second anode. The first organic light emitting layer may not overlap the second organic light emitting layer.

The first organic light emitting layer may emit red light, and the second organic light emitting layer may emit green or blue light. The first organic light emitting layer may be in direct contact with the second organic light emitting layer on the first anode.

The substrate may include a third emitting region positioned on another side of the first emitting region, and the organic light emitting display device may include a third anode on the third emitting region, and a third organic light emitting layer on the another part of the first anode and the third anode, the third organic light emitting layer including a material different from the first organic light emitting layer and the second organic light emitting layer.

The third organic light emitting layer may be on an edge portion of the first anode that faces the third anode. The third

organic light emitting layer may extend from an upper portion of the third anode to an upper edge portion of the first anode that faces the third anode. The first organic light emitting layer may not overlap the second organic light emitting layer and the third organic light emitting layer. The first organic light emitting layer may be in direct contact with the second organic light emitting layer and the third organic light emitting layer on the first anode.

The device may include a cathode over an entire surface of the substrate and facing the first anode and the second anode, wherein the first organic light emitting layer and the second organic light emitting layer are between the cathode and the first and second anodes.

In accordance with another embodiment, an organic light emitting display device includes a substrate with a first emitting region adjacent a second emitting region; a first anode in the first emitting region; a first organic light emitting layer on the first anode and including a first emitting material to emit a first color; a second organic light emitting layer on the first organic light emitting layer and including a second emitting material to emit light of a second color different from the first color; a second anode in the second emitting region; and a third organic light emitting layer on the second anode and including the second emitting material. The first color may be red and the second color may be green or blue.

The second organic light emitting layer may include a third emitting material to emit light of a third color different from the first color and the second color, the substrate includes a third emitting region on another side of the first emitting region, and the organic light emitting display device includes: a third anode in the third emitting region; and a fourth organic light emitting layer on the third anode and including the third emitting material.

The device may include a cathode over an entire surface of the substrate and facing the first anode and the second anode, wherein the first organic light emitting layer and the second organic light emitting layer are between the cathode and the first and second anodes.

In accordance with another embodiment, an organic light emitting display device includes a substrate with a first emitting region adjacent a second emitting region; a first anode in the first emitting region; a first organic light emitting layer on the first anode and including a first material to emit light of a first color and a second material to emit light of a second color; a second anode in the second emitting region; and a second organic light emitting layer on the second anode and including the second emitting material. The first color may be red and the second color may be green or blue.

The first organic light emitting layer may include a third emitting material to emit light of a third color different from the first color and the second color, the substrate may include a third emitting region on another side of the first emitting region, and the organic light emitting display device may include a third anode in the third emitting region; and a fourth organic light emitting layer on the third anode and including the third emitting material. The device may include a cathode over an entire surface of the substrate and facing the first anode and the second anode, wherein the first organic light emitting layer and the second organic light emitting layer are between the cathode and the first and second anodes.

BRIEF DESCRIPTION OF THE DRAWINGS

Features will become apparent to those of skill in the art by describing in detail exemplary embodiments with reference to the attached drawings in which:

FIG. 1 illustrates an embodiment of an organic light emitting display device;

FIG. 2 illustrates a view along section line II-II' in FIG. 1;

FIG. 3 illustrates an example of a color coordinate system for color correction;

FIG. 4 illustrates an example of a color coordinate system including portion IV in FIG. 3;

FIG. 5 illustrates an example of a color coordinate system with a side visibility improvement effect;

FIG. 6 illustrates an example of color shift curves;

FIG. 7 illustrates another embodiment of an organic light emitting display;

FIG. 8 illustrates a view along section line VIII-VIII' in FIG. 7;

FIG. 9 illustrates another example of a color coordinate system for color correction;

FIG. 10 illustrates another embodiment of an organic light emitting display;

FIG. 11 illustrates a view along section line XI-XI' in FIG. 10; and

FIGS. 12 and 13 illustrate another embodiment of an organic light emitting display device.

DETAILED DESCRIPTION

Example embodiments will now be described more fully hereinafter with reference to the accompanying drawings; however, they may be embodied in different forms and should not be construed as limited to the embodiments set forth herein. Rather, these embodiments are provided so that this disclosure will be thorough and complete, and will fully convey exemplary implementations to those skilled in the art.

In the drawing figures, the dimensions of layers and regions may be exaggerated for clarity of illustration. It will also be understood that when a layer or element is referred to as being "on" another layer or substrate, it can be directly on the other layer or substrate, or intervening layers may also be present. Further, it will be understood that when a layer is referred to as being "under" another layer, it can be directly under, and one or more intervening layers may also be present. In addition, it will also be understood that when a layer is referred to as being "between" two layers, it can be the only layer between the two layers, or one or more intervening layers may also be present. Like reference numerals refer to like elements throughout.

FIG. 1 illustrates an embodiment of an organic light emitting display device 100, and FIG. 2 is a cross-sectional view taken along line II-II' in FIG. 1. Referring to FIGS. 1 and 2, the organic light emitting display device 100 includes a substrate 110, a plurality of anodes 120a, 120b, and 120c, a pixel defining layer 130, a hole transfer layer 140, a plurality of organic light emitting layers 150a, 150b, and 150c, a plurality of auxiliary layers 150a' and 150c', an electron transfer layer 160, and a cathode 170.

The substrate 110 may be or include an insulating substrate. The insulating substrate may be formed of a transparent glass material having, for example, transparent SiO₂ as a main component. In one embodiment, the insulating substrate may be made of an opaque material or a plastic material. Further, the insulating substrate may be a flexible substrate that may bend, fold, or be rolled.

The substrate 110 may further include other structures formed on the insulating substrate. Examples include but are not limited to wiring and an insulating layer. If the organic light emitting display device 100 is an active organic light emitting display device, the substrate 110 may include a

plurality of thin film transistors on the insulating substrate. Each thin film transistor may include a gate electrode, a source electrode, a drain electrode, and a semiconductor layer including a channel region. The semiconductor layer may be formed, for example, of amorphous silicon, microcrystalline silicon, polycrystalline silicon, monocrystalline silicon, or oxide semiconductor. The drain electrodes of one or more of the thin film transistors may be electrically connected to the anodes 120a, 120b, and 120c.

The substrate 110 may include a plurality of emitting regions E1, E2, and E3, and a non-emitting region NE. The emitting regions E1, E2, and E3 emit light. The non-emitting region NE do not emit light. Further, the emitting regions E1, E2, and E3 include the anodes 120a, 120b, and 120c, which are exposed by the pixel defining layer 130. The non-emitting region NE includes the pixel defining layer 130. The emitting regions E1, E2, and E3 may be formed to be spaced from each other. The non-emitting region NE may surround the emitting regions E1, E2, and E3. Further, the emitting regions E1, E2, and E3 may emit light having different colors.

The emitting regions E1, E2, and E3 include the first emitting region E1, the second emitting region E2, and the third emitting region E3. The first emitting region E1, the second emitting region E2, and the third emitting region E3 may correspond to a first pixel (or sub-pixel), a second pixel (or sub-pixel), and a third pixel (or sub-pixel), respectively. The sub-pixels may be included in a same pixel.

The first emitting region E1, the second emitting region E2, and the third emitting region E3 may emit a first, second, and third color light. The first, second, and the third color may be red, blue, and green, respectively. In another embodiment, one or more different color or white light may be emitted.

In this embodiment, the first emitting region E1 is between the second and third emitting regions E2 and E3. That is, the second and third emitting regions E2 and E3 are adjacent respective sides of the first emitting region E1. In the embodiment of FIG. 2, the second emitting region E2 is left of the first emitting region E1, and the third emitting region E3 is right of the first emitting region E1.

The anodes 120a, 120b, and 120c are on the substrate 110 and are spaced from each other. For example, the anodes 120a, 120b, and 120c may be positioned in respective ones of the emitting regions E1, E2, and E3. That is, the anodes 120a, 120b, and 120c are formed to be mutually separated from each other by pixels (or sub-pixels). The anodes 120a and 120b, and 120c may be independently driven, and may function to transfer holes to the hole transfer layer 140 and respective ones of the organic light emitting layers 150a, 150b, and 150c.

The anodes 120a, 120b, and 120c may be made of a conductive material having, for example, a high work function. If the organic light emitting display device 110 is a bottom emission-type display device, the anodes 120a, 120b, and 120c may be formed of a material including but not limited to ITO, IZO, ZnO, or In₂O₃, or a laminated layer thereof. If the organic light emitting display device 100 is a top emission-type display device, the anodes 120a, 120b, and 120c may further include a reflective layer, which is formed, for example, of Ag, Mg, Al, Pt, Pd, Au, Ni, Nd, Ir, Cr, Li, or Ca.

The anodes 120a, 120b, and 120c may be modified in various ways, for example, to have a structure of two or more layers using two or more different materials. The

anodes **120a**, **120b**, and **120c** may be formed, for example, through a sputtering process using a fine metal mask (FMM).

The anodes **120a**, **120b**, and **120c** include the first anode **120a**, the second anode **120b**, and the third anode **120c**. The first anode **120a**, the second anode **120b**, and the third anode **120c** may be respectively positioned in the first emitting region E1, the second emitting region E2, and the third emitting region E3. The first anode **120a**, the second anode **120b**, and the third anode **120c** may be made of the same material or may be made of different materials.

The pixel defining layer **130** is on the substrate **110** and the anodes **120a**, **120b**, and **120c**. The pixel defining layer **130** exposes at least a portion of the anodes **120a**, **120b**, and **120c**. For example, regions where the pixel defining layer **130** is not positioned may correspond to the emitting regions E1, E2, and E3. A region where the pixel defining layer **130** is positioned may correspond to the non-emitting regions NE.

The pixel defining layer **130** may be made of an insulating material. In one embodiment, the pixel defining layer **130** may be made of at least one organic material selected from the group including benzo cyclo butene (BCB), polyimide (PI), poly amide (PA), acrylic resin, and phenol resin, or may be made of an inorganic material such as silicon nitride.

The hole transfer layer **140** may be positioned on the anodes **120a**, **120b**, and **120c** and the pixel defining layer **130**. In one embodiment, the hole transfer layer **140** may be commonly formed over the entire surface of the substrate **110**. The hole transfer layer **140** may be formed, for example, by a deposition process using an open mask. The hole transfer layer **140** may be selectively formed only on the emitting regions E1, E2, and E3. The hole transfer layer **140** may function to transfer holes from the anode to the organic light emitting layers **150a**, **150b**, and **150c**.

The hole transfer layer **140** may include at least one of a hole injecting layer or a hole transport layer. The hole injecting layer may be in direct contact with at least one of the anodes **120a**, **120b**, and **120c**, and the hole transport layer may be in direct contact with at least one of the organic light emitting layers **150a**, **150b**, and **150c**.

The hole injecting layer may include a hole injecting material, e.g., phthalocyanine compounds including but not limited to copper phthalocyanine, TCTA or m-MTDATA of starburst-type amine derivatives, Pani/DBSA (Polyaniline/Dodecylbenzenesulfonic acid) or PEDOT/PSS (poly(3,4-ethylenedioxythiophene)/Poly(4-styrenesulfonate) that is conducting polymer, Pani/CSA (Polyaniline/Camphor sulfonic acid), or PANI/PSS (Polyaniline)/Poly (4-styrene-sulfonate).

The hole transport layer may include a hole transport material, e.g., 1,3,5-tricarbazolylbenzene, 4,4'-biscarbazolylbiphenyl, polyvinylcarbazol, m-biscarbazolylphenyl, 4,4'-biscarbazolyl-2,2'-dimethylbiphenyl, 4,4',4"-tri(N-carbazolyl) triphenylamine, 1,3,5-tri (2-carbazolylphenyl)benzene, 1,3,5-tris (2-carbazolyl-5-methoxyphenyl) benzene, bis (4-carbazolylphenyl)silane, N,N'-bis(3-methylphenyl)-N, N'-diphenyl-[1,1'-biphenyl]-4,4' diamine (TDP), N,N'-di (naphthalene-1-yl)-N,N'-diphenyl benzidine (NPD), N,N'-dephenyl-N,N'-bis(1-naphthyl)-(1,1'-biphenyl)-4,4'-diamine (NPB), poly(9,9-dioctylfluorene-co-N-(4-butylphenyl) diphenylamine) (TFB), or (poly(9,9-dioctylfluorene-co-bis-(4-butylphenyl-bis-N,N-phenyl-1,4-phenylenediamin) (PFB), but is not limited thereto.

The organic light emitting layers **150a**, **150b**, and **150c** are on the hole transfer layer **140**. The organic light emitting layers **150a**, **150b**, and **150c** emit light of specific colors. For

example, in the plurality of organic light emitting layers **150a**, **150b**, and **150c**, holes and electrons provided from anodes **120a**, **120b**, and **120c** and the cathode **170** recombine to form excitons. As the energy level of the excitons changes, light of specific colors (e.g., red, green, blue, yellow, white, etc.) are emitted.

The organic light emitting layers **150a**, **150b**, and **150c** include the first organic light emitting layer **150a**, the second organic light emitting layer **150b**, and the third organic light emitting layer **150c**. The first organic light emitting layer **150a**, the second organic light emitting layer **150b**, and the third organic light emitting layer **150c** may be made of different materials. The first organic light emitting layer **150a** may include a first emitting material that emits a first-color light, the second organic light emitting layer **150b** may include a second emitting material that emits a second-color light that is different from the first color, and the third organic light emitting layer **150c** may include a third emitting material that emits a third-color light that is different from the first color and the second color.

The first color, the second color, and the third color may be, for example, red, blue, and green respectively, or a different combination of colors including white. For example, the first organic light emitting layer **150a**, the second organic light emitting layer **150b**, and the third organic light emitting layer **150c** may emit red light, blue light, and green light, respectively.

If the first organic light emitting layer **150a** emits red light, the first organic light emitting layer **150a** may be made of a high-molecular material, a low-molecular material, or a high/low-molecular mixed material which inherently emits red light. In one embodiment, the red organic light emitting layer may include a red host material and a red dopant material. The red host material may be, for example, at least one selected from the group including {Bis(2-(2-hydroxyphenyl)benzothiazolato) zinc (Zn(BTZ)₂)} and {Bis(2-methyl-8-quinolinolate)-4-(phenylphenolate)aluminium}, but is not limited thereto. The red dopant material may include, for example, PtOEP, Ir(piq)₃, Btp₂Ir(acac) or DCJTb.

If the second organic light emitting layer **150b** emits blue light, the second organic light emitting layer **150b** may be made of a high-molecular material, a low-molecular material, or a high/low-molecular mixed material which inherently emits blue light. In one embodiment, the blue organic light emitting layer may include a blue host material and a blue dopant material. The blue host material may be, for example, at least one selected from the group including anthracene derivatives and carbazole-based compound. The anthracene derivatives may be, for example, 9,10-(2-dinaphthyl)anthracene (AND). The carbazole-based compound may be, for example, 4,4'-(carbazole-9-yl) biphenyl (CBP). The blue dopant material may include, for example, F₂Irpic, (F₂ppy)₂Ir(tmd), Ir(dfppz)₃, or ter-fluorene.

If the third organic light emitting layer **150c** emits green light, the third organic light emitting layer **150c** may be made of a high-molecular material, a low-molecular material, or a high/low-molecular mixed material which inherently emits green light. In one embodiment, the green organic light emitting layer may include a green host material and a green dopant material. The green host material may be, for example, at least one selected from the group including anthracene derivatives and carbazole-based compound. The anthracene derivatives may be, for example, 9,10-(2-dinaphthyl)anthracene (AND). The carbazole-based compound may be, for example, 4,4'-(carbazole-9-yl) biphe-

nyl (CBP). The green dopant material may include, for example, Ir(ppy)₃ (ppy=phenylpyridine), Ir(ppy)₂(acac), Ir(mppy)₃, or C545T.

The first organic light emitting layer **150a** may be positioned on the first anode **120a** in the first emitting region E1. In one embodiment, the first organic light emitting layer **150a** may be positioned on the remaining region except for part of the first anode **120a** in the first emitting region E1. For example, the first organic light emitting layer **150a** may be positioned on an edge portion **20** of the first anode **120a** that faces the second anode **120b**, for example, on the remaining region except for the left edge portion. The first organic light emitting layer **150a** may be positioned on the whole surface of the first anode **120a** in the first emitting region E1.

The second organic light emitting layer **150b** may be positioned on part of the first anode **120a** in the first emitting region E1 and in the second emitting region E2. In one embodiment, the second organic light emitting layer **150b** may be on the whole surface of the second anode **120b** in the second emitting region E2. Further, the second organic light emitting layer **150b** may be not only in the second emitting region E2, but also part of the first emitting region E1.

The part of the first emitting region E1 may correspond to an edge portion of the first anode **120a** that faces the second anode **120b**, for example, the left edge portion. In this case, the second organic light emitting layer **150b** may be formed to extend from the upper portion of the second anode **120b** to the upper portion of the edge portion **20** of the first anode **120a** that faces the second anode **120b**. For example, the second organic light emitting layer **150b** may completely cover the pixel defining layer **130** that is between the first anode **120a** and the second anode **120b**.

The first organic light emitting layer **150a** and the second organic light emitting layer **150b** may not overlap each other. For example, the second organic light emitting layer **150b** may be on part of the first anode **120a** that is positioned in the first emitting region E1 and may be in the region except for the part of the first anode **120a**. The first organic light emitting layer **150a** and the second organic light emitting layer **150b** may overlap each other in the first emitting region E1.

The first organic light emitting layer **150a** may be in direct contact with the second organic light emitting layer **150b** on the first anode **120a**, that is positioned in the first emitting region E1. In one embodiment, the side surface of the first organic light emitting layer **150a** may be in direct contact with the second organic light emitting layer **150b**.

The third organic light emitting layer **150c** may be on the third anode **120c** that is positioned in the third emitting region E3. In one embodiment, the third organic light emitting layer **150c** may be on the whole surface of the third anode **120c** that is positioned in the third emitting region E3.

Although the first organic light emitting layer **150a** is positioned on most of the region of the first anode **120a** in the first emitting region E1, the second organic light emitting layer **150b** may be on a partial region of the first anode **120a** in the first emitting region E1. On the other hand, the second organic light emitting layer **150b** may be on the whole surface of the second anode **120b** in the second emitting region E2. The third organic light emitting layer **150c** may be on the whole surface of the third anode **120c** in the third emitting region E3.

The auxiliary layers **150a'** and **150c'** may be between at least a part of the organic light emitting layers **150a**, **150b**, and **150c** and the hole transfer layer **140**. The auxiliary layers **150a'** and **150c'** may function to adjust a resonance

distance in each pixel (or sub-pixel). For example, the auxiliary layers **150a'** and **150c'** may function to heighten the color purity and light emitting efficiency of light emitted from the organic light emitting layers **150a**, **150b**, and **150c**. The auxiliary layers **150a'** and **150c'** may include the first auxiliary layer **150a'** and the second auxiliary layer **150c'**.

The first auxiliary layer **150a'** may be between the first organic light emitting layer **150a** and the hole transfer layer **140**. The first auxiliary layer **150a'** may completely overlap the first organic light emitting layer **150a**. In one embodiment, the first auxiliary layer **150a'** may be successively formed together with the first organic light emitting layer **150a** in the same chamber. The first auxiliary layer **150a'** may function to adjust the resonance distance of the first-color light emitted from the first organic light emitting layer **150a**. For example, the first auxiliary layer **150a'** may adjust the distance between the first anode **120a** and the cathode **170** in the first emitting region E1. In one embodiment, the first auxiliary layer **150a'** may include, for example, at least one selected from the group including silicon nitride (SiNx), silicon oxide (SiO₂), and silicon oxynitride (SiO_N).

The second auxiliary layer **150c'** may be between the third organic light emitting layer **150c** and the hole transfer layer **140**. The second auxiliary layer **150c'** may completely overlap the third organic light emitting layer **150c**. In one embodiment, the second auxiliary layer **150c'** may be successively formed together with the third organic light emitting layer **150c** in the same chamber. The second auxiliary layer **150c'** may function to adjust the resonance distance of the third-color light emitted from the third organic light emitting layer **150c**. For example, the second auxiliary layer **150c'** may adjust the distance between the third anode **120c** and the cathode **170** in the third emitting region E3.

The thickness of the second auxiliary layer **150c'** may be different from (e.g., thinner than) the thickness of the first auxiliary layer **150a'**. Further, the second auxiliary layer **150c'** may be made of the same or a different material as the material of the first auxiliary layer **150a'**. The second auxiliary layer **150c'** may include, for example, at least one selected from the group including silicon nitride (SiNx), silicon oxide (SiO₂), and silicon oxynitride (SiO_N).

The electron transfer layer **160** may be positioned on the organic light emitting layers **150a**, **150b**, and **150c** and the pixel defining layer **130**. In one embodiment, the electron transfer layer **160** may be commonly formed on the whole surface of the substrate **110**. The electron transfer layer **160** may be formed, for example, by a deposition process using an open mask. In one embodiment, the electron transfer layer **160** may be selectively formed only on the emitting regions E1, E2, and E3. The electron transfer layer **160** may function to transfer electrons from the cathode **170** to the organic light emitting layers **150a**, **150b**, and **150c**.

The electron transfer layer **160** may include at least one of an electron injecting layer or an electron transport layer. The electron injecting layer may be in direct contact with the cathode **170**. The electron transport layer may be in direct contact with the organic light emitting layers **150a**, **150b**, and **150c**.

The electron injecting layer may include an electron injecting material. The electron injecting material may include, for example, at least one of LiF, LiQ, or NaQ. As another example, the electron injecting material may include NaCl, CsF, Li₂O, or BaO.

The electron transport layer may include an electron transport material. The electron transport material may include, for example, at least one of a pyrene series material, a triazine series material, or an anthracene series material.

As another example, the electron transport material may include materials such as but not limited to quinoline derivatives, and particularly, tris(8-quinolinolate)aluminum (Alq3), TAZ, and Balq.

The cathode 170 may be positioned on the electron transfer layer 160. In one embodiment, the cathode 170 may be commonly formed on the whole surface of the substrate 110. The cathode 170 may be formed, for example, by a deposition process using an open mask. In one embodiment, the cathode 170 may be selectively formed only on the emitting regions E1, E2, and E3. The cathode 170 may function to provide electrons to the organic light emitting layers 150a, 150b, and 150c.

FIGS. 3 and 4 illustrate an example of color correction effects of the organic light emitting display device 100. More specifically, FIG. 3 illustrates an embodiment of a color coordinate system explaining color correction effects of an organic light emitting display device, which, for example, may correspond to device 100 in FIG. 1. FIG. 4 illustrates an example of a color coordinate system with portion IV in FIG. 3 enlarged. Moreover, FIGS. 3 and 4 illustrate the color coordinates as seen from a front perspective of the organic light emitting display device 100.

First, referring to FIG. 3, in a CIE color coordinate system: R corresponds to the color coordinates of light of a first color (e.g., red) emitted from the first organic light emitting layer 150a; B corresponds to the color coordinates of light of a second color (e.g., blue) emitted from the second organic light emitting layer 150b; and C corresponds to the color coordinates of light of a third color (e.g., green) emitted from the third organic light emitting layer 150c. The R, G, and B color coordinates form a standard triangle (ST).

If only the first organic light emitting layer 150a is positioned on the first emitting region E1, only the second organic light emitting layer 150b is positioned on the second emitting region E2, and only the third organic light emitting layer 150c is positioned on the third emitting region E3, the organic light emitting display device 100 emits light having color coordinates in the standard triangle ST.

If the first organic light emitting layer 150a is unable to emit high-purity red light (e.g., if the y color coordinates of light emitted from the first organic light emitting layer 150a are larger than the y color coordinates of high-purity red light), the organic light emitting display device 100 may not properly express high-purity red color. In this case, color correction may be performed so that the organic light emitting display device 100 expresses high-purity red color. As illustrated in FIGS. 1 and 2, color correction may be performed by arranging not only the first organic light emitting layer 150a that emits the red light, but also the second organic light emitting layer 150b that emits the blue light.

Referring to FIGS. 3 and 4, as the ratio of the area of the second organic light emitting layer 150b to the area of the first organic light emitting layer 150a in the first emitting region E1 increases, the color coordinates R may move in the direction of an arrow on one side of the standard triangle ST. In one embodiment, the color coordinates of light emitted from the first emitting region E1 of the organic light emitting display device 100 of FIG. 1 may be set to R'.

For example, through proper adjustment of the area of the second organic light emitting layer 150b in the first emitting region E1, the y color coordinates of the color coordinates R' of light emitted from the first emitting region E1 may equally match the y color coordinates of the red color coordinates of the sRGB color coordinate system. In this case, high-purity red light may be emitted from the first

emitting region E1. In this case, R', B, and G form a changed triangle CH, and the organic light emitting display device 100 of FIG. 1 may emit light having the color coordinates in the changed triangle CH.

FIGS. 5 and 6 illustrate an example of side visibility improvement effects of the organic light emitting display device 100 according to one embodiment. FIG. 5 illustrates an example of a color coordinate system explaining a side visibility improvement effect of the organic light emitting display device 100. FIG. 6 is a graph in which line A-A' and line B-B' of the color coordinate system are converted to color shift curves according to their angles.

First, referring to FIG. 5, A indicates the color coordinates when light emitted from the first emitting region E1 is seen from a front surface of the organic light emitting display device 100 (e.g., the direction of a normal line of the display surface of the organic light emitting display device 100) in the case where only the first organic light emitting layer 150a is positioned on the first emitting region E1. A' indicates color coordinates when light emitted from the first emitting region E1 is seen from a side surface of the organic light emitting display device 100 (e.g., the direction that is oriented 60 degrees from the normal line of the display surface of the organic light emitting display device 100) in the case where only the first organic light emitting layer 150a is positioned on the first emitting region E1. As described above, if the organic light emitting display device 100 is seen as moving from the front surface to the side surface of the organic light emitting display device 100, the color coordinates of the red light, and in particular, the y color coordinates, may abruptly change in the direction of the arrow.

B indicates color coordinates when light emitted from the first emitting region E1 is seen from the front surface of the organic light emitting display device 100 (e.g., the direction of the normal line of the display surface of the organic light emitting display device 100) in the case where not only the first organic light emitting layer 150a, but also the second organic light emitting layer 150b, is positioned on the first emitting region E1. B' indicates color coordinates when light emitted from the first emitting region E1 is seen from the side surface of the organic light emitting display device 100 (e.g., the direction oriented 60 degrees from the normal line of the display surface of the organic light emitting display device 100) in the case where not only the first organic light emitting layer 150a, but also the second organic emitting layer 150b, is positioned on the first emitting region E1.

As described above, if the organic light emitting display device 100 is seen as moving from the front surface to the side surface of the organic light emitting display device 100, the color coordinates of the red light may change in the direction of the arrow, but the variation of the y color coordinates is not relatively large. A main factor that influences visibility is the y color coordinates. If two lights are combined in the first emitting region E1 to form mixed light, the side visibility of the mixed light becomes higher than the side visibility of non-mixed light.

Referring to FIG. 6, curve X corresponds to line A-A' in FIG. 5 for conversion of a color shift curve according to the angle thereof. Curve Y corresponds to line B-B' in FIG. 5 for conversion to a color shift curve according to the angle thereof. As illustrated in FIG. 6, as the angle at which the organic light emitting display device 100 is seen increases, curve Y (e.g., the color shift of the mixed light) decreases and becomes smaller than the color shift of the non-mixed light. Thus, by arranging not only the first organic light emitting layer 150a, but also the second organic light

emitting layer **150b**, in the first emitting region E1, the visibility of red light is improved.

FIG. 7 illustrates another embodiment of an organic light emitting display **101**, and FIG. 8 is across-sectional view taken along line VIII-VIII' in FIG. 7. Referring to FIGS. 7 and 8, a first organic light emitting layer **151a**, a second organic light emitting layer **151b**, a third organic light emitting layer **151c**, a first auxiliary layer **151a'**, and a second auxiliary layer **151c'** may be made of the same materials as the first organic light emitting layer **150a**, the second organic light emitting layer **150b**, the third organic light emitting layer **150c**, the first auxiliary layer **150a'**, and the second auxiliary layer **150c'**, respectively.

However, the first organic light emitting layer **151a** may be positioned on a remaining area except for part of the first anode **120a** on the first emitting layer. The second organic light emitting layer **151b** may be positioned on an entire surface of the second anode **120b** on the second emitting region E2, and the third organic light emitting layer **151c** may be positioned on part of the first anode **120a** on the first emitting region E1 and on the entire surface of the third anode **120c** on the third light emitting region E3.

Here, the part of the first emitting region E1 may correspond to an edge portion of the first anode **120a** that faces the third anode **120c**, e.g., the right edge portion. In this case, the third organic light emitting layer **151c** may extend from the upper portion of the third anode **120c** to the upper edge portion of the first anode **120a** that faces the third anode **120c**. Further, the first auxiliary layer **151a'** may completely overlap the third organic light emitting layer **151c**, and may be formed on the lower portion of the third organic light emitting layer **151c**.

FIG. 9 illustrates an example of a color coordinate system explaining color correction effects of the organic light emitting display device in FIG. 7. Referring to FIG. 9, as a ratio of the area of the third organic light emitting layer **151c** to the area of the first organic light emitting layer **151a** in the first emitting region E1 increases, the color coordinates R may move in the direction of an arrow along one side of the standard triangle ST. In one embodiment, the color coordinates of light emitted from the first emitting region E1 of the organic light emitting display device **101** in FIG. 7 may be R". In this case, R", B, and G form a changed triangle CH', and the organic light emitting display device **101** in FIG. 7 may emit the light having color coordinates in the changed triangle CH'.

FIG. 10 illustrates another embodiment of an organic light emitting display device **102**, and FIG. 11 is a view taken along section line XI-XI' in FIG. 10. Referring to FIGS. 10 and 11, a first organic light emitting layer **152a**, a second organic light emitting layer **152b**, a third organic light emitting layer **152c**, a first auxiliary layer **152a'**, and a second auxiliary layer **152c'** may be made of the same materials as the first organic light emitting layer **150a**, the second organic light emitting layer **150b**, the third organic light emitting layer **150c**, the first auxiliary layer **150a'**, and the second auxiliary layer **150c'**, respectively.

However, the first organic light emitting layer **152a** may be positioned on the center portion of the first anode **120a** positioned on the first emitting layer. The second organic light emitting layer **152b** may be positioned on part of the first anode **120a** on the first emitting region E1 and on the entire surface of the second anode **120b** on the second emitting region E2. The third organic light emitting layer **152c** may be positioned on another part of the first anode **120a** on the first emitting region E1 and on the entire surface of the third anode **120c** on the third light emitting region E3.

Here, the part of the first emitting region E1 may correspond to an edge portion of the first anode **120a** that faces the second anode **120b**, e.g., the left edge portion. The other part of the first light emitting region E1 may correspond to an edge portion of the first anode **120a** that faces the third anode **120c**, e.g., the right edge portion. In this case, the second organic light emitting layer **152b** may extend from the upper portion of the second anode **120b** to the upper edge portion of the first anode **120a** that faces the second anode **120b**. The third organic light emitting layer **152c** may extend from the upper portion of the third anode **120c** to the upper edge portion of the first anode **120a** that faces the third anode **120c**.

Further, the first auxiliary layer **152a'** may completely overlap the first organic light emitting layer **152a**, and may be formed on the lower portion of the first organic light emitting layer **152a**. The second auxiliary layer **152a'** may completely overlap the third organic light emitting layer **152c**, and may be formed on the lower portion of the third organic light emitting layer **152c**. Further, the first organic light emitting layer **152a** may not overlap the second organic light emitting layer **152b** and the third organic light emitting layer **152c**. Further, the first organic light emitting layer **152a** may directly contact the second organic light emitting layer **152b** and the third organic light emitting layer **152c** on the first anode **120a**.

FIG. 12 illustrates another embodiment of an organic light emitting display device **103**. Referring to FIG. 12, the first organic light emitting layer **153a** may be made of the same material as the first organic light emitting layer **150a** as described above. For example, the first organic light emitting layer **153a** includes a first emitting material that emits light of a first color, e.g., red. The first organic light emitting layer **153a** may be positioned on the entire surface of the first anode **120a** on the first emitting region E1.

A second organic light emitting layer **153b** may be positioned on the first organic light emitting layer **153a**. The second organic light emitting layer **153b** may include a second light emitting material that emits light of a second color (e.g., blue), and/or a third organic light emitting material that emits light of a third color, e.g., green.

An intermediate layer **180** may be between the first organic light emitting layer **153a** and the second organic light emitting layer **153b**. The intermediate layer **180** may include a charge generating layer **180c** between a sub-electron transfer layer **180a**, a sub-hole transfer layer **180b**. The sub-electron transfer layer **180a** is adjacent to the first organic light emitting layer **153a**, and may be made of the same material as the electron transfer layer **160**. The sub-hole transfer layer **180b** is adjacent to the second organic light emitting layer **153b**, and is made of the same material as the hole transfer layer **140**. The charge generating layer **180c** generates electrons and holes.

The electrons generated from the charge generating layer **180c** may be transferred to the first organic light emitting layer **153a** through the sub-electron transfer layer **180a**. The holes generated from the charge generating layer **180c** may be transferred to the second organic light emitting layer **153b** through the sub-hole transfer layer **180b**. The charge generating layer **180c** may prevent the electrons and holes from moving in opposite directions.

In the organic light emitting display device **103** according to another embodiment, the first auxiliary layer **150a'** may be omitted. In this case, the function of the first auxiliary layer **150a'** as described above (i.e., the resonance distance adjustment function) may be performed by the intermediate layer **180**.

The third organic light emitting layer **153c** may be made of the same material as the second organic light emitting layer **153b** as described above. That is, the third organic light emitting layer **153c** may include a second light emitting material that emits light of the second color. The third organic light emitting layer **153c** may be on the entire surface of the second anode **120b** on the second emitting region E2.

A fourth organic light emitting layer **153d** may be made of the same material as the third organic light emitting layer **153c** as described above. That is, the fourth organic light emitting layer **153d** may include a third light emitting material that emits light of the third color. The fourth organic light emitting layer **153d** may be on the entire surface of the third anode **120c** on the third emitting region E3.

The second auxiliary layer **153d'** may be made of the same material as the second auxiliary layer **150c'** as described above. The second auxiliary layer **153d'** may completely overlap the fourth organic light emitting layer **153d** on the lower portion of the fourth organic light emitting layer **153d**.

Because the first organic light emitting layer **153a** and the second organic light emitting layer **153b** overlap each other in the first emitting region E1, the color of light emitted from the first emitting region E1 may be corrected.

FIG. 13 is a cross-section view of another embodiment of an organic light emitting display device **104**. Referring to FIG. 13, the first organic light emitting layer **154a** may include a second emitting material and/or a third emitting material in addition to the first emitting material. For example, the first organic light emitting layer **154a** may include a mixture of a plurality of emitting materials. The first organic light emitting layer **154a** may be positioned on the entire surface of the first anode **120a** in the first emitting region E1.

The first auxiliary layer **154a'** may be made of the same material as the first auxiliary layer **150a'** as described above. The first auxiliary layer **154a'** may be formed to completely overlap the first organic light emitting layer on the lower portion of the first organic light emitting layer.

The second organic light emitting layer **154b** may be made of the same material as the second organic light emitting layer **150b** as described above. For example, the second organic light emitting layer **154b** may include a second light emitting material. The second organic light emitting layer **154b** may be positioned on the entire surface of the second anode **120b** in the second emitting region E2.

The third organic light emitting layer **154c** may be made of the same material as the third organic light emitting layer **150c** as described above. For example, the third organic light emitting layer **154c** may include a third light emitting material that emits the third-color light. The third organic light emitting layer **154c** may be on the entire surface of the third anode **120c** on the third emitting region E3.

The second auxiliary layer **154c'** may be made of the same material as the second auxiliary layer **150c'** as described above. The second auxiliary layer **154c'** may be formed to completely overlap the third organic light emitting layer **154c** on the lower portion of the third organic light emitting layer **154c**.

As described above, because the first organic light emitting layer **154a** includes the second emitting material and/or the third emitting material in addition to the first emitting material, the color of light emitted from the first emitting region E1 may be corrected.

By way of summation and review, in one type of organic light emitting display device, a plurality of emitting layers are included to emit light of different colors. For example, a

first emitting layer emits light of a first color, a second emitting layer emits light of a second color, and a third emitting layer emits light of a third color. A particular color is emitted by combining the light of the first to third colors.

However, if at least any one of the first to third emitting layers does not properly emit light of a specific color, the color expression of the organic light emitting display device may deteriorate. For example, if the first emitting layer in a red pixel emits low-purity red light (e.g., orange light) rather than high-purity red light, the organic light emitting display device that includes the first emitting layer may not properly display the red color.

Further, the low-purity red light emitted from the first emitting layer may have low side visibility. Accordingly, when a display surface of the organic light emitting display device is seen from the side of the organic light emitting display device, the purity of the red light emitted from the first emitting layer may be further lowered.

In accordance with one or more of the aforementioned embodiments, an organic light emitting display device is provided which has improved color expression and side visibility.

Example embodiments have been disclosed herein, and although specific terms are employed, they are used and are to be interpreted in a generic and descriptive sense only and not for purpose of limitation. In some instances, as would be apparent to one of skill in the art as of the filing of the present application, features, characteristics, and/or elements described in connection with a particular embodiment may be used singly or in combination with features, characteristics, and/or elements described in connection with other embodiments unless otherwise indicated. Accordingly, it will be understood by those of skill in the art that various changes in form and details may be made without departing from the spirit and scope of the present invention as set forth in the following claims.

What is claimed is:

1. An organic light emitting display device, comprising:
 - a substrate with a first emitting region adjacent a second emitting region;
 - a hole transfer layer in the first emitting region and the second emitting region;
 - a first organic light emitting layer in the first emitting region and not in the second emitting region;
 - a second organic light emitting layer in the first emitting region and the second emitting region;
 - an electron transfer layer in the first emitting region and the second emitting region;
 - a first anode in the first emitting region;
 - a first auxiliary layer between the first organic light emitting layer and the first anode; and
 - a second anode in the second emitting region,
 wherein the first emitting region emits a first color light and the second emitting region emits a second color light, the second color different from the first color, wherein the first organic light emitting layer is on the first anode, and the second organic light emitting layer is on the second anode and a part of the first anode, wherein the first organic light emitting layer does not overlap the second anode in a direction perpendicular to an upper surface of the substrate, wherein the first organic light emitting layer and the second organic light emitting layer in the first light emitting region are between the hole transfer layer and the electron transfer layer, and

15

wherein the first auxiliary layer is only in the first emitting region, the first auxiliary layer being between the first organic light emitting layer and the hole transfer layer.

2. The organic light emitting display device as claimed in claim 1, wherein a part of the second organic light emitting layer is on an edge portion of the first anode that faces the second anode.

3. The organic light emitting display device as claimed in claim 2, wherein the second organic light emitting layer extends from an upper portion of the second anode to an upper portion of an edge portion of the first anode that faces the second anode.

4. The organic light emitting display device as claimed in claim 1, further comprising:

a cathode over an entire surface of the substrate and facing the first anode and the second anode, wherein the first organic light emitting layer and the second organic light emitting layer are between the cathode and the first and second anodes.

5. The organic light emitting display device as claimed in claim 1, wherein:

the first organic light emitting layer is to emit red light, and

the second organic light emitting layer is to emit green or blue light.

6. The organic light emitting display device as claimed in claim 1, wherein the first organic light emitting layer is in direct contact with the second organic light emitting layer in the first emitting region.

7. The organic light emitting display device as claimed in claim 1, wherein the hole transfer layer is in direct contact with the first and second anodes, a portion of the hole transfer layer being directly between the second anode and the second organic light emitting layer in the second emitting region.

8. An organic light emitting display device, comprising: a substrate with a first emitting region adjacent a second emitting region;

a hole transfer layer in the first emitting region and the second emitting region;

a first organic light emitting layer in the first emitting region and not in the second emitting region;

a second organic light emitting layer in the first emitting region and the second emitting region;

a first anode in the first emitting region;

a first auxiliary layer between the first organic light emitting layer and the first anode; and

a second anode in the second emitting region,

wherein the first emitting region emits a first color light and the second emitting region emits a second color light, the second color different from the first color,

wherein the first organic light emitting layer is on the first anode, and the second organic light emitting layer is on the second anode and a part of the first anode, and

wherein the substrate includes a third emitting region positioned on another side of the first emitting region, wherein the organic light emitting display device includes a third anode in the third emitting region, and a third

16

organic light emitting layer on the third anode and another part of the first anode,

wherein the third emitting region emits a third color light, the third color different from the first color and the second color, and

wherein the first auxiliary layer is only in the first emitting region, the first auxiliary layer being between the first organic light emitting layer and the hole transfer layer.

9. The organic light emitting display device as claimed in claim 8, wherein a part of the third organic light emitting layer is on an edge portion of the first anode that faces the third anode.

10. The organic light emitting display device as claimed in claim 9, wherein the third organic light emitting layer extends from an upper portion of the third anode to an upper portion of an edge portion of the first anode that faces the third anode.

11. The organic light emitting display device as claimed in claim 8, wherein the first organic light emitting layer is in direct contact with the second organic light emitting layer and the third organic light emitting layer in the first emitting region.

12. An organic light emitting display device, comprising: a substrate with a first emitting region adjacent a second emitting region;

a hole transfer layer in the first emitting region and the second emitting region;

a first organic light emitting layer in the first emitting region and not in the second emitting region;

a second organic light emitting layer in the first emitting region and the second emitting region; and

an electron transfer layer in the first emitting region and the second emitting region;

wherein the first emitting region emits a first color light and the second emitting region emits a second color light, the second color different from the first color,

wherein the device further comprises a first anode in the first emitting region; and a second anode in the second emitting region,

wherein the first organic light emitting layer is disposed on the first anode, and the second organic light emitting layer is disposed on the second anode and a part of the first anode,

wherein the first organic light emitting layer does not overlap the second anode in a direction perpendicular to an upper surface of the substrate,

wherein the first organic light emitting layer and the second organic light emitting layer in the first light emitting region are disposed between the hole transfer layer and the electron transfer layer, and

wherein the hole transfer layer is in direct contact with the second organic light emitting layer in the first light emitting region and the hole transfer layer is not in direct contact with the first organic light emitting layer in the first light emitting region.

* * * * *

专利名称(译)	有机发光显示装置		
公开(公告)号	US10622577	公开(公告)日	2020-04-14
申请号	US15/847077	申请日	2017-12-19
[标]申请(专利权)人(译)	三星显示有限公司		
申请(专利权)人(译)	三星DISPLAY CO. , LTD.		
当前申请(专利权)人(译)	三星DISPLAY CO. , LTD.		
[标]发明人	CHOI SANG HYUN YUN YOUNG NAM		
发明人	CHOI, SANG HYUN YUN, YOUNG NAM		
IPC分类号	H01L51/50 H01L51/52 H01L27/32		
CPC分类号	H01L51/5036 H01L27/3211 H01L27/3209 H01L51/5265		
优先权	1020140069418 2014-06-09 KR		
其他公开文献	US20180108856A1		
外部链接	Espacenet		

摘要(译)

一种有机发光显示装置，包括：基板，其具有与第二发光区域相邻的第一发光区域；在第一发光区域中的第一阳极；在第一阳极上的第一有机发光层；在第二发光区域中的第二阳极；以及 在第一阳极和第二阳极的一部分上的第二有机发光层。第二有机发光层包括与第一有机发光层不同的材料。

